

Technical book

EP7 Range
3,0 to 5,0 tons
Pallet trucks High capacity



- Pedestrian
- Ride on 6 km/h
- Lateral exchange battery



3000 - 5000 kg

TECHNICAL SPECS

				MANITOU			
				MANITOU	MANITOU	MANITOU	
Specifications	1.1	Manufacturer			MANITOU	MANITOU	MANITOU
	1.2	Model			EP 730	EP 740	EP 750
	1.3	Power source			Battery	Battery	Battery
	1.4	Driving position			Pedestrian	Pedestrian	Pedestrian
	1.5	Nominal capacity	Q	kg	3000	4000	5000
	1.6	Load centre of gravity	c	mm	600	600	600
	1.8	Distance centre to fork face (forks lowered/raised)	x	mm	890	890	890
Weight	1.9	Wheelbase	y	mm	1570	1570	1570
	2.1	Operating weight		kg	870	870	910
Tyres, frame	3.1	Wheel type (front/rear)			Polyurethane	Polyurethane	Polyurethane
	3.2	Size of drive wheel		mm	1x(Ø320x120)	1x(Ø320x120)	1x(Ø320x120)
	3.3	Tyres size (load side)		mm	4x(Ø80x100)	4x(Ø80x100)	4x(Ø80x100)
	3.4	Size of cator wheels		mm	2x(Ø150x50)	4x(Ø150x50)	4x(Ø150x50)
	3.5	Number of front wheels (x=drive wheel) / rear wheels			1x + 2/4	1x + 4/4	1x + 4/4
	3.6	Front wheel gauge (middle of wheels)	b10	mm	890	890	890
	3.7	Rear wheel gauge (middle of wheels)	b11	mm	500	500	500
Dimensions	4.4	Lift height	h3	mm	195 ⁺⁵⁻⁰	195 ⁺⁵⁻⁰	195 ⁺⁵⁻⁰
	4.9	Tiller arm in vertical position	h14	mm	1380	1380	1380
	4.15	Fork height in low position	h13	mm	85 ⁺⁵⁻⁰	85 ⁺⁵⁻⁰	85 ⁺⁵⁻⁰
	4.19	Overall length	l1	mm	1890	1890	1890
	4.20	Lenght at fork heels	l2	mm	740	740	740
	4.21	Total width (overall)	b1	mm	975	975	975
	4.22	Forks dimensions	s / e / l	mm	200x60x1150	200x60x1150	200x60x1150
	4.25	Fork spread	b5	mm	570*	570*	570*
	4.32	Ground clearance at centre of wheel-base	m2	mm	25	25	25
	4.34	Width of aisle for pallet 800 x 1200 lenghtways	Ast	mm	2090	2090	2090
4.35	Turning radius (forks lowered/raised)	Wa	mm	1645/1605	1645/1605	1645/1605	
Performances	5.1	Speed of travel laden / unladen		km/h	6/5	6/5	6/5
	5.2	Speed of raise laden / unladen		m/s	0,03 / 0,038	0,03 / 0,038	0,03 / 0,038
	5.3	Speed of lowering laden / unladen		m/s	0,05 / 0,05	0,05 / 0,05	0,05 / 0,05
	5.8	Maximum climbing ability, with / without load		%	8/5	8/5	8/5
	5.10	Service brake			Sepex Variator	Sepex Variator	Sepex Variator
Motors	6.1	Drive motor, 60 minute rating		kW	1,7	1,7	1,7
	6.2	lift motor rating at 10%y		kW	2	2	3
	6.3	Battery according to DIN 43531/35/36,A,B,C			-	-	-
	6.4	Battery voltage/rated capacity (5h)		V/Ah	24/240**	24/315**	24/315**
	6.5	Battery weight		kg	240	315	315
Misc	8.1	Speed control			Sepex Variator	Sepex Variator	Sepex Variator

* Others dimensions are available.

** Further alternatives are available.

DIMENSIONAL DRAWINGS

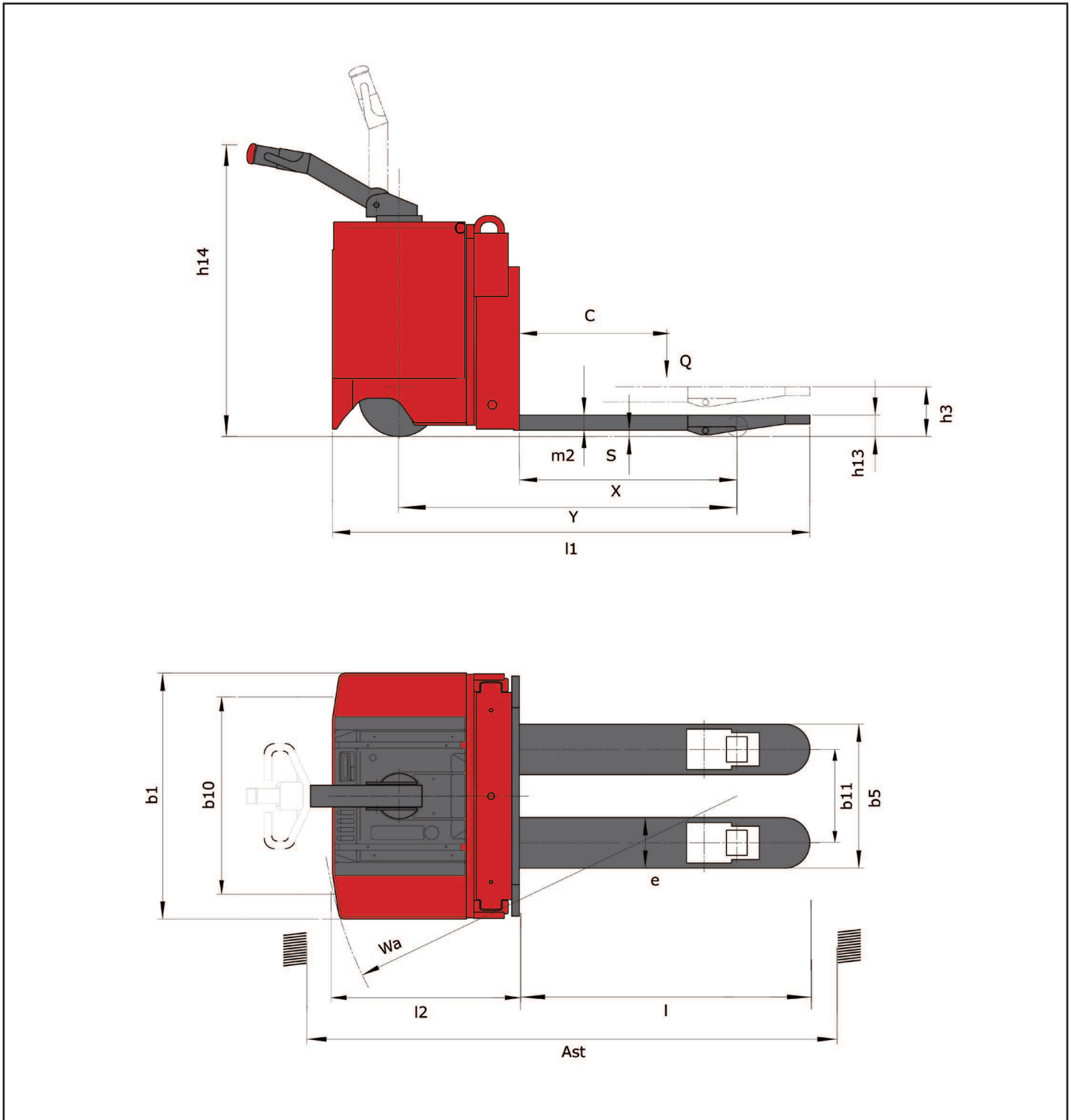

Your nearest MANITOU dealer :



Head office

B.P. 249 - 430 rue de l'Aubinière - 44158 Ancenis Cedex - France
Tel: 00 33 (0)2 40 09 10 11 - Fax: 00 33 (0)2 40 09 10 97
www.manitou.com

This brochure describes versions and configuration options for Manitou products which may be fitted with different equipment. The equipment described in this brochure may be standard, optional or not available depending on version. Manitou reserves the right to change the specifications shown and described at any time and without prior warning. The manufacturer is not liable for the specifications given. For more information, contact your Manitou dealer. Non-contractual document. Product descriptions may differ from actual products. List of specifications is not comprehensive. The logos and visual identity of the company are the property of Manitou and may not be used without authorisation. All rights reserved. The photos and diagrams contained in this brochure are provided for information only.

MANITOU BF SA - Limited company with board of directors - Share capital: 39,547,824 euros - 857 802 508 RCS Nantes