

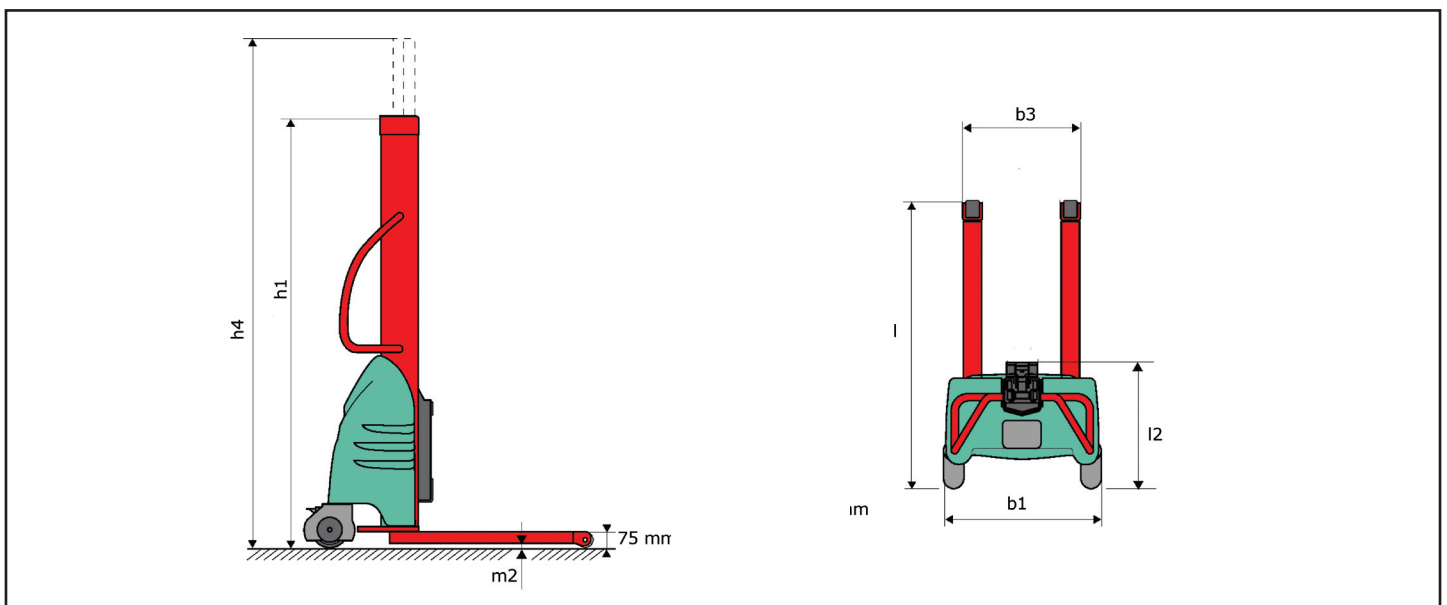

		MANITOU	MANITOU	MANITOU	MANITOU	MANITOU
		EB 250 D18	EB 250 D25	EB 500 D18	EB 500 D25	EB 1000 S16
	Q	kg	250	500	1000	
	c	mm				
		kg	155	170	220	240 260
		mm	2x (75x65)			4x (75x65)
		mm	2x (150x50)			
	h1	mm	1585	1815	1600	1950 1990
	h3	mm	1780	2480	1780	2480 1570
	h4	mm	2475	3055	2490	3190 1990
	h13	mm				
	l1	mm	1032	1300	1330	
	l2	mm	571	575	570	
	b1	mm	710			
	b3	mm	529	519	520	
	m2	mm	40	35	25	
		m/s	0,075			
		m/s	0,1			
		kW	1,2			
		V/Ah	12/110			
		kg				

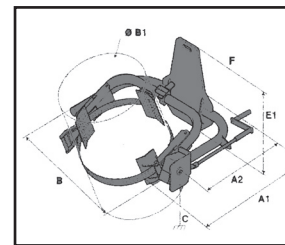

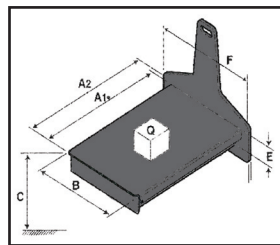
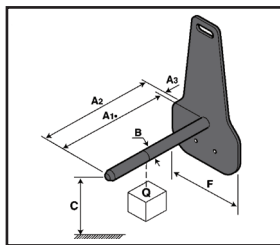
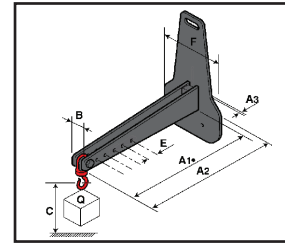
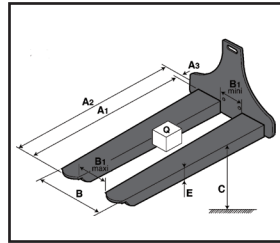
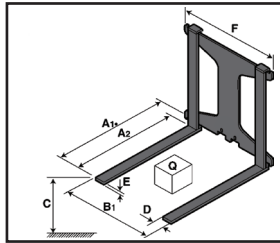

			A1	A2	B	B1		C	D	E	E1	E2	F	
	kg		mm	mm	mm	min mm	max. mm	mm	mm	mm	mm	mm	mm	kg
FA 250	250	250	500	540		230	650	50	50	20			680	33
POT 250	150	400	425	440	50			170					320	22
EPE 250	250	250	500	515	50			270					320	21
PLF 250	200	300	620	635	40			280		88			630	40

			A1	A2	B	B1		C	D	E	E1	E2	F	
	kg		mm	mm	mm	min mm	max. mm	mm	mm	mm	mm	mm	mm	kg
FA 500	500	350	700	745		250	680	45	60	30			720	54
FR 500	500	600	1150	1177	560	200	315	85		70			700	68
POT 500	250	600	625	652	50			150					320	25
EPE 500	500	350	700	715	50			252					320	30
PLF 500	500	350	700	727	600			280		91			630	50
FUT 500	300	600	795	600	1057	350	650	245		240	631			92

			A1	A2	B	B1		C	D	E	E1	E2	F	
	kg		mm	mm	mm	min mm	max. mm	mm	mm	mm	mm	mm	mm	kg
FA 1000	1000	500	950	1017		190	710	45	80	40			730	123
FR 1000	1000	600	1150	1182	560	200	320	90		70			700	82
POT 1000	500	600	625	652	50			145					320	33
EPE 1000	1000	350	700	730	60			245					320	38
PLF 1000	1000	350	700	727	600			275		91			630	65
FUT 1000	300	600	795	600	1057	350	650	245		240	631			92

				MANITOU	MANITOU	MANITOU	MANITOU	MANITOU
				HM 250 D18	HM 250 D25	HM 500 D18	HM 500 D25	HM 1000 S16
		Q	kg	250		500		1000
		c	mm					
			kg	110	110	178	190	220
			mm	2x (75x65)				4x (75x65)
			mm	2x (150x50)				2x (160x40)
		h1	mm	1585	1815	1600	1950	1990
		h4	mm	2475	3055	2490	3190	1990
		h3	mm	1780	2480	1780	2480	1570
		h13	mm					
		l1	mm	1032		1300		1330
		l2	mm	571		575		570
		b1	mm	710				
		b3	mm	529		519		520
		m2	mm	40		35		25
			m/s	0,1				

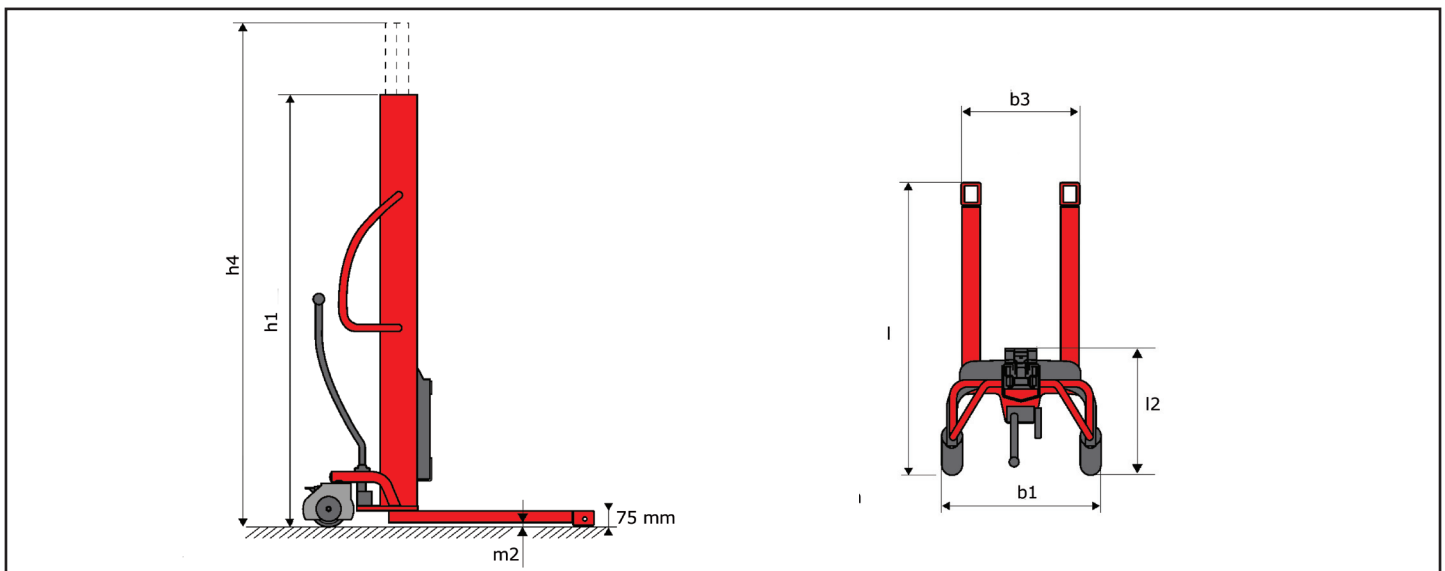

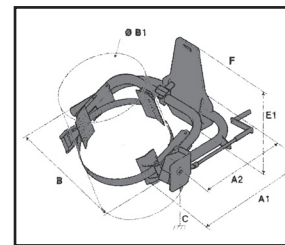
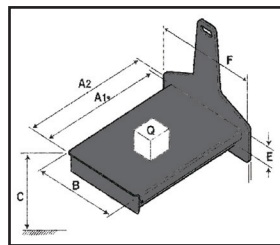
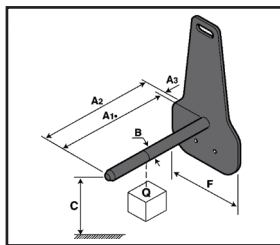
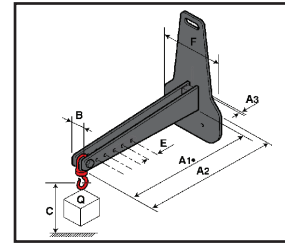
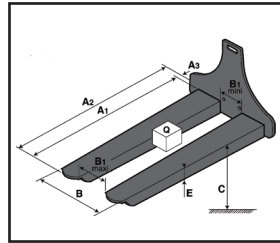
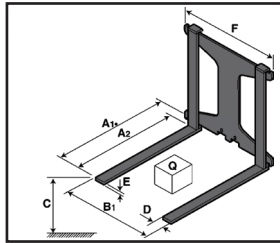

			A1	A2	B	B1		C	D	E	E1	E2	F	
	kg		mm	mm	mm	min mm	max. mm	mm	mm	mm	mm	mm	mm	kg
FA 250	250	250	500	540		230	650	50	50	20			680	33
POT 250	150	400	425	440	50			170					320	22
EPE 250	250	250	500	515	50			270					320	21
PLF 250	200	300	620	635	40			280		88			630	40

			A1	A2	B	B1		C	D	E	E1	E2	F	
	kg		mm	mm	mm	min mm	max. mm	mm	mm	mm	mm	mm	mm	kg
FA 500	500	350	700	745		250	680	45	60	30			720	54
FR 500	500	600	1150	1177	560	200	315	85		70			700	68
POT 500	250	600	625	652	50			150					320	25
EPE 500	500	350	700	715	50			252					320	30
PLF 500	500	350	700	727	600			280		91			630	50
FUT 500	300	600	795	600	1057	350	650	245		240	631			92

			A1	A2	B	B1		C	D	E	E1	E2	F	
	kg		mm	mm	mm	min mm	max. mm	mm	mm	mm	mm	mm	mm	kg
FA 1000	1000	500	950	1017		190	710	45	80	40			730	123
FR 1000	1000	600	1150	1182	560	200	320	90		70			700	82
POT 1000	500	600	625	652	50			145					320	33
EPE 1000	1000	350	700	730	60			245					320	38
PLF 1000	1000	350	700	727	600			275		91			630	65
FUT 1000	300	600	795	600	1057	350	650	245		240	631			92

					<b>MANITOU</b>
					<b>DHM 250 D15</b>
			Q	kg	250
			c	mm	
				kg	95
				mm	2x(50x20)
				mm	2x(250x40)
			h1	mm	1305
			h3	mm	1480
			h4	mm	2043
			h13	mm	
			l1	mm	911
			l2	mm	516
			b1	mm	666
			m2	mm	45

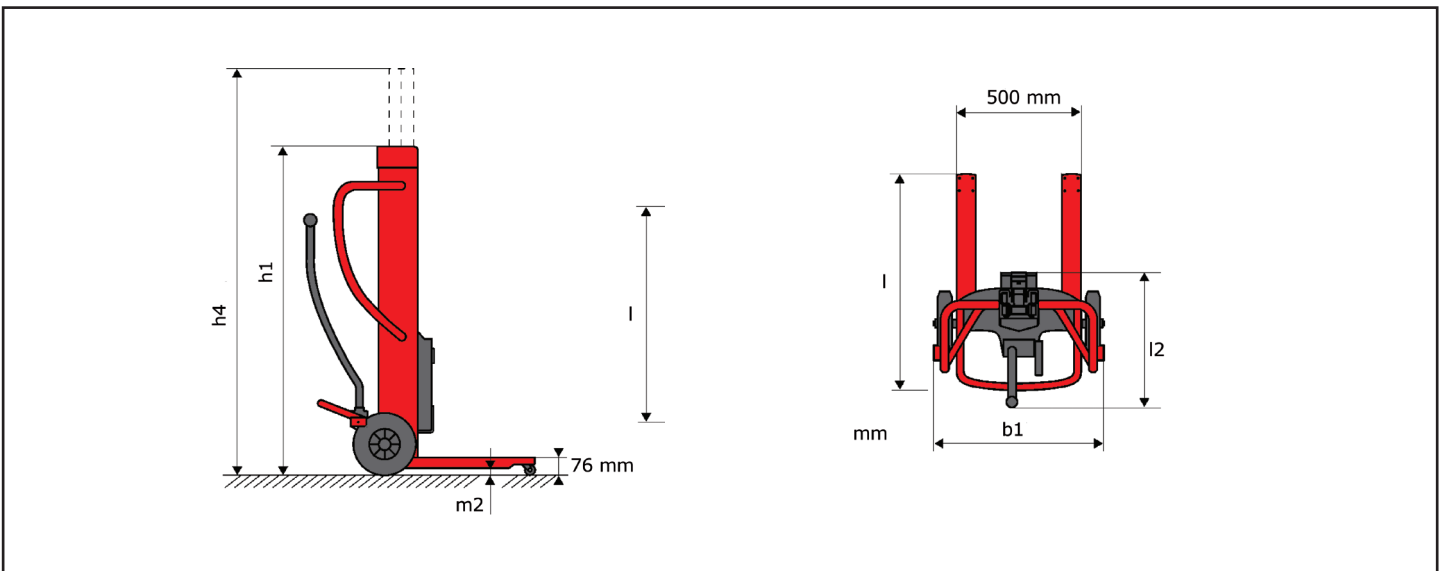

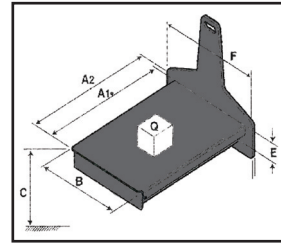
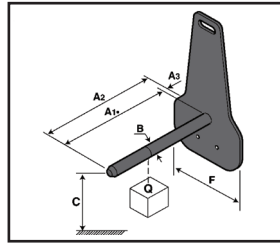
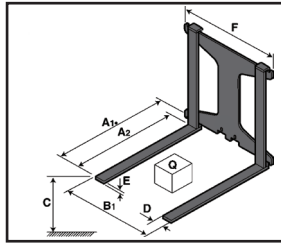

	Q		A1	A2	B	B1		C	D	E	E1	E2	F	
	kg		mm	mm	mm	min mm	max. mm	mm	mm	mm	mm	mm	mm	kg
FA 250	250	250	500	540		230	650	50	50	20			680	33
EPE250	250	250	500	515	50			270					320	21
PLF 250	200	300	620	635	40			280		88			630	40

