

90 V'Air

Vertical platforms



Technical specs

90 V Air

	Working height	mm	9000
	Platform height	mm	7000
	Basket outreach	mm	2041
	Tail swing	mm	40
	Turret rotation	°	350
	Capacity	kg	230
	Number of persons (indoor/outdoor)		2 / 2
	Basket (width x length) Space / floor surface	mm	950 x 680 / 755 x 600
1	Overall width	mm	1110
2	Overall length	mm	2310
3	Overall height	mm	2310
4	Interior turning circle	mm	550
5	Exterior turning circle	mm	1980
6	Maximum ground clearance (under frame)	mm	95
7	Minimum ground clearance (under frame)	mm	30
	Wheelbase	mm	1200
	Speed of forward movement	km/h	4,5
	Working speed	km/h	0,6
	Maximum slope accessible (with 200 kg)	%	25,1
	Maximum tilt	° - %	2 / 3,5
	Tyre size	mm	405 x 127
	Driving wheels		2 (arrière)
	Steering/directional wheels		2 (avant)
	Weight (varies according to options & standards of the country)	kg	2710
	Driving motors	kW	2 x 1,5
	Electropump	kW	1 x 2,2
	Hydraulic tank capacity	L	22
	Battery	Ah / V	250 / 24
	Integrated charger	Ah / V	30 / 24
	Number of EARL cycle (with / without light)		39 / 30
	Ground pressure (on hard floor)	daN / cm ²	18,6
	Maximum available pressure	Bar	140
	Level of vibration		< 2,5 m/s ²
	Sound level	dB	<70

Equipments

standard

- Proportional switches/levers
- Forward movement possible at maximum height
- Sound and visual alarm in case of excessive slant and overload
- Integrated charger
- Emergency manual descent
- Negative braking system on rear wheels
- Sound warning system inside the platform
- Hour meter
- Indication of state of charge of batteries
- Hooks for sling loading/lifting
- Integrated diagnostic aid
- Tyres with non-marking edges
- Basket with mesh floor
- Bus CAN technology
- Tool box inside platform
- Traction battery with centralised filing

Aeronautical standard

- Front and side rubber protections
- 2 LED headlights with protections
- 2 rear position lamps
- side retro-reflectors
- 3 Anti-static braids
- 2 radars with vertical detection (anti-collision system)
- Illuminated control panel
- specific basket with different working position
- Dry powder 6 kg fire extinguisher

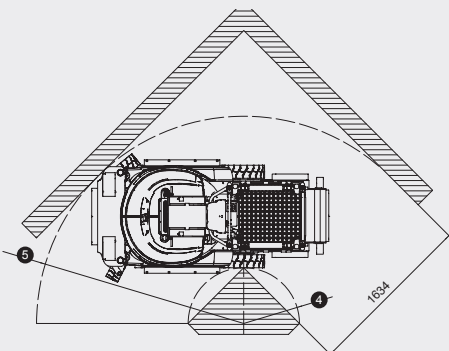
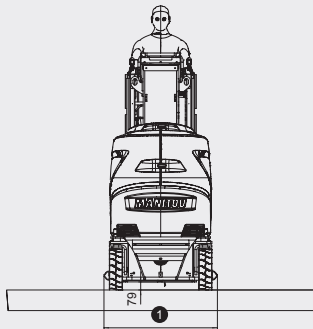
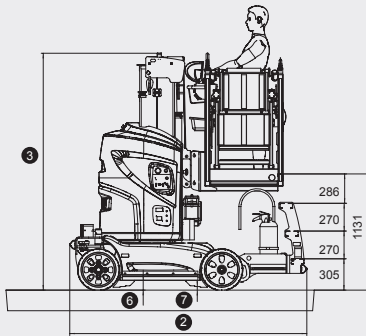
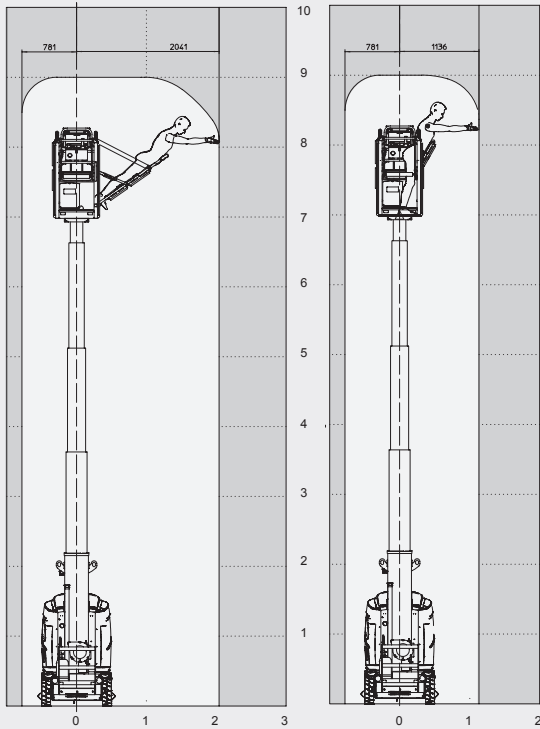



Head office:
 B.P. 249 - 430 rue de l'Aubinière - 44158 Ancenis Cedex - France
 Tel: 00 33 (0)2 40 09 10 11- Fax: 00 33 (0)2 40 09 10 97
www.manitou.com

This brochure describes versions and configuration options for MANITOU products which may be fitted with different equipment. The equipment described in this brochure may be standard, optional or not available depending on version. MANITOU reserves the right to change the specifications shown and described at any time and without prior warning. The manufacturer is not liable for the specifications given. For more information, contact your MANITOU dealer. Non-contractual document. Product descriptions may differ from actual products. List of specifications is not comprehensive. The logos and visual identity of the company are the property of MANITOU and may not be used without authorisation. All rights reserved. The photos and diagrams contained in this brochure are provided for information only. MANITOU BF SA - Limited company with board of directors - Share capital: 39.547.824 euros - 857 802 508 RCS Nantes